

World's Lightest, Strongest, & Most Durable Speed Bumps and Parking Blocks

SPEED BUMPS

- Improve pedestrian and vehicle safety!
- Reduce traffic to a safe speed!



- Durable - Will last season after season
- Weather resistant - Never warp, chip, rot, or corrode
- Environmentally Friendly - Manufactured from 100% recycled material
- Modular - Unlimited design possibility
- Portable - Can be moved for snow removal or surface maintenance
- Low maintenance - Very little or no maintenance required
- Simple Installation - No heavy machinery required
- Affordable - Lightweight for economical shipping - Costs a portion of the cost of concrete
- Colorful - Highly visible day or night to both drivers and pedestrians

PARKING BLOCKS

- Keep vehicles from obstructing walkways and lawns!
- Stop Drivers from parking too close to buildings!



APPLICATIONS

- Residential Roads
- Laneways
- Residential Indoor Garages
- Parking Lots
- Drive-Thru
- Great Vehicle Stopper
- Shopping Centers
- Commercial Indoor Garages
- Hospitals

SPEED BUMPS AND PARKING BLOCKS

Bump it or Block it...we've got you covered!

SPEED BUMPS Economic, Modular & Light Weight

- Yellow Plates: Each speed bump section is embedded with (6) reflective yellow safety plates of weather resistant, composite material for protection from salt, freeze and thaw.
- End Cap: 5" (127mm) Safety Snap On End Cap - sloped modular profile prevents tripping by pedestrians.
- Can be used as a cable cover - bottom sides include 1" x 1½" (25 mm x 38 mm) channels for protecting temporary or permanent cables or hoses.
- Weighs only 10lbs (4.5kg)/piece. - Ships at a fraction of the cost of heavier speed bumps.
- Size: 36" long x 10.5" wide x 2" high-main piece (914mm long x 267mm wide x 51mm high)
- A standard speed bump system section includes (2) main pieces, (2) end caps x 5" long (127mm) and (1) connector clip. Main pieces may be added and connected to form larger units.
- Made of Recycled PVC.
- Its Flexibility allows it to contour to road crown.

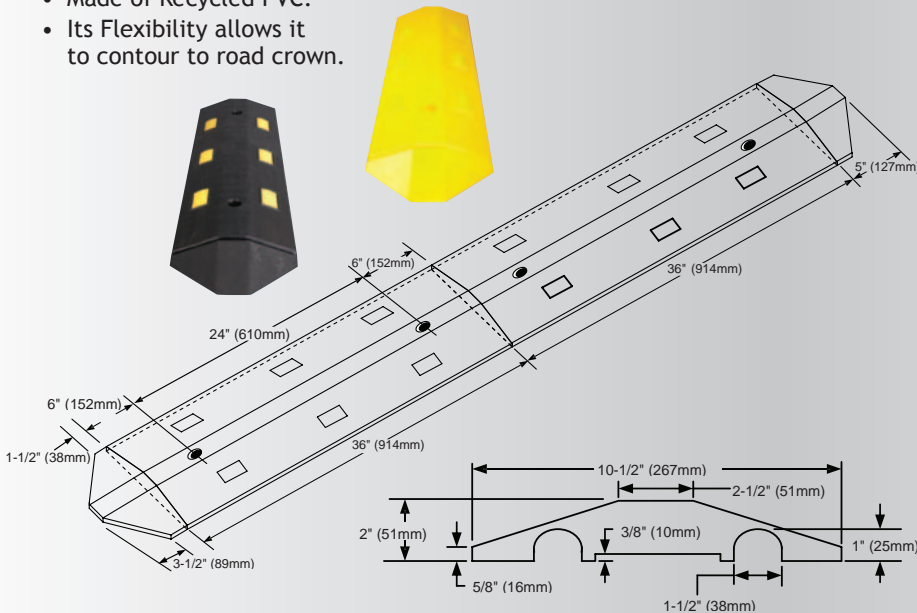

INSTALLATION STYLES

- Asphalt installations will be supplied (2) 12" (305 mm) long spikes
- Concrete installations are supplied (2) 8" (203mm) lag bolts with anchoring sleeve

PARKING BLOCKS Simple, Affordable & Colorful

- Eliminate brittle concrete replacements with 100% recycled plastic parking blocks engineered to prevent warp, crack, chip and rot
- Unlimited design possibilities with modular design and multiple colors; safety yellow, grey or blue
- Lightweight 4lbs (1.8kg) per piece for economical shipment and simple, one-person installation without use of heavy machinery
- No painting needed—UV treated for ultimate durability and low-maintenance
- Modular connectors are supplied with any multiple piece order

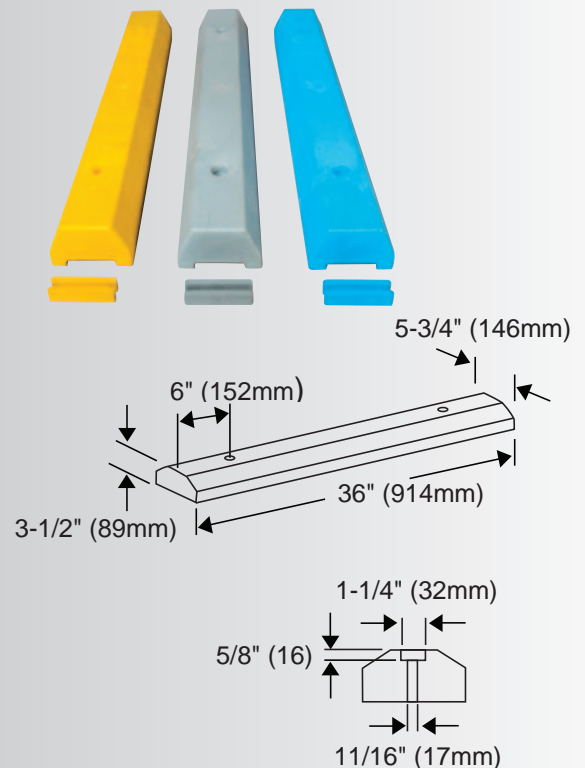

OTHER DBS PRODUCTS

Dock Lights



Trailer Stands



Knuffi

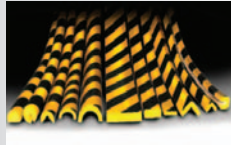

Bumpers



Traffic Control System



Wheel Chocks

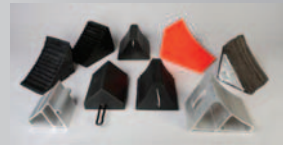

Dock Bumper Solutions Inc.
www.doksolutions.com

181 Regina Road
Vaughan ON, Canada L4L 8M3

Tel: 905-850-4015
E-mail: info@doksolutions.com
Web: www.doksolutions.com

 **DBS**
Driven to Satisfy